

---

# **USER MANUAL**

**MODEL NUMBER:**

**SP-25N**

**SP-25NK**

**SP-25NV**

**AND RELATED UNITS**

**25 Gallon (94.6 Liters) Air Operated  
Portable Spray Equipment**

---

**English (Original Instructions)**

---

## READ ALL INSTRUCTIONS BEFORE OPERATING EQUIPMENT

# WARNING



**Read this manual completely and understand the machine before operating or servicing it.**

- Read all instructions before installing or operating unit.
- Always wear appropriate personal protective equipment (PPE) when operating or servicing unit.
- Always follow all chemical safety precautions and handling instructions provided by the chemical manufacturer and Safety Data Sheet (SDS).
- Never point the discharge trigger gun at yourself, another person, or any object you do not want covered in chemical.
- Always depressurize unit after use (as described in the After Use Instructions), and store unit depressurized.
- Do not exceed an incoming air pressure of 100 psi (7 bar).
- Do not exceed a fluid temperature of 100°F (37°C).
- Only use clean and dry air. Air must be filtered and free of moisture or pump life will be diminished. If needed, install an air dryer before unit.
- Do not use an air lubricator before the unit.
- Never use unit with hydrocarbons or flammable products.

### PROTECT THE ENVIRONMENT

Please dispose of packaging materials, old machine components, and hazardous fluids in an environmentally safe way according to local waste disposal regulations.



Always remember to recycle.

\*Specifications and parts are subject to change without notice.

### Options:

	Pump Seal Material
SP-25N	Santoprene ( <i>standard</i> )
	Viton ( <b>V</b> )
	Kalrez ( <b>K</b> )

Add bold option codes to item number as shown. For standard options, no option code is needed.

### Examples:

- SP-25N (standard unit with Santoprene pump seals)
- SP-25NV (unit with Viton pump seals)

## READ ALL INSTRUCTIONS BEFORE OPERATING EQUIPMENT

<b>REQUIREMENTS</b>	
Compressed air requirements	40-80 psi (3-5 bar) with 2 cfm (28.3 l/min)
Liquid temperature range	40-100°F (4.4-37°C)
Chemical compatibility	Chemical products used with this equipment must be formulated for this type of application and compatible with unit materials and pump seals. For more information on chemical compatibility, consult the manufacturer or SDS for your product or contact our customer service department.

<b>SPECIFICATIONS</b>	
Power type	Compressed air
Chemical pickup type	Draws from pre-mixed solution
Number of products unit can draw from	One product
Suction line length/diameter	3/8 in. (9.5 mm) inside diameter
Capacity	25 gallons (94.6 liters)
Discharge hose diameter/length	30 ft. (9 m) hose, with 3/8 in. (9.5 mm) inside diameter
Discharge wand/tip type	Polypropylene trigger handle with 25° fan tip
Output distance	10-12 ft. (3.0-3.7 m)
Output volume	2 gal/min (7.6 l/min)
Flow rate*	2 gal/min (7.6 l/min)
Pump seals	Santoprene, Viton, or Kalrez
Wheel type	Two 10 inch non-marking wheels, Two 3 inch casters with lock
*Dilution rates and flow rates given are based on chemical with viscosity of water and factory air pressure settings.	

## READ ALL INSTRUCTIONS BEFORE OPERATING EQUIPMENT

### Operation Instructions

Wearing all PPE and observing all safety precautions dictated by the MSDS for your chemical:

1. Fill the tank with the solution to be sprayed.
2. Connect an appropriate compressed air line into the air inlet fitting (AP25).
3. Squeeze the discharge trigger gun (PSG12) to begin spraying.

### After Use Instructions:

1. Flush the unit with fresh water for 5 minutes.
2. Disconnect the air line from the air fitting (AP25) and relieve any pressure remaining in the system by squeezing the discharge trigger gun (PSG12).
3. Release the discharge trigger gun (PSG12) after all pressure has been relieved from the system.

### Maintenance Instructions:

To keep your portable unit operating properly, periodically perform the following maintenance procedures:

- Check the air pump (P56/P56K/P56V) for wear and leaks.
- Inspect hoses for leaks or excessive wear. Make sure all hose clamps are in good condition and properly secured.
- Replace filter (AFR25) in regulator (R25) as needed.
- Check the suction tube and screen for debris and clean as needed.
- Drain compressor tank on a regular basis to ensure proper operation of pump.

### Troubleshooting Instructions:

- Check to ensure that the discharge hose is uncoiled properly, and that there are no kinks that could obstruct fluid flow.
- Check the air regulator bowl (ABR25) and air filter (AFR25) for debris such as water, oil, or rust particles. Clean by unthreading the air regulator bowl (ABR25) from the air regulator (R25).
- Check the strainer (STR38-IL) for debris or other blockages, and clean as needed. Replace strainer if damaged. Strainer must be used.
- If air passes through the pump (P56/P56K/P56V) without cycling, the pump needs to be replaced.
- Check for proper air pressure on the air gauge (AG100). The air regulator (R25) is factory set at 50 psi (3.4 bar). Operating range is 40 to 80 PSI (3 to 5 bar) with 2 CFM (56.6 l/min).
- If the unit operates at a reduced pressure:
  - Check the air compressor supplying the unit. If the pressure is less than 40 psi, turn the unit off until the compressor can catch up.
  - If the air supply is 50 psi (3.4 bar) or above, check the air gauge (AG100), which should read near 50 psi (3.4 bar). If the air gauge reads more or less than 50 psi (3.4 bar), adjust the pressure by turning the knob on the top of the air regulator (R25).

# READ ALL INSTRUCTIONS BEFORE OPERATING EQUIPMENT

## TANK ASSEMBLY ITEM NUMBER: TANK-25N-A

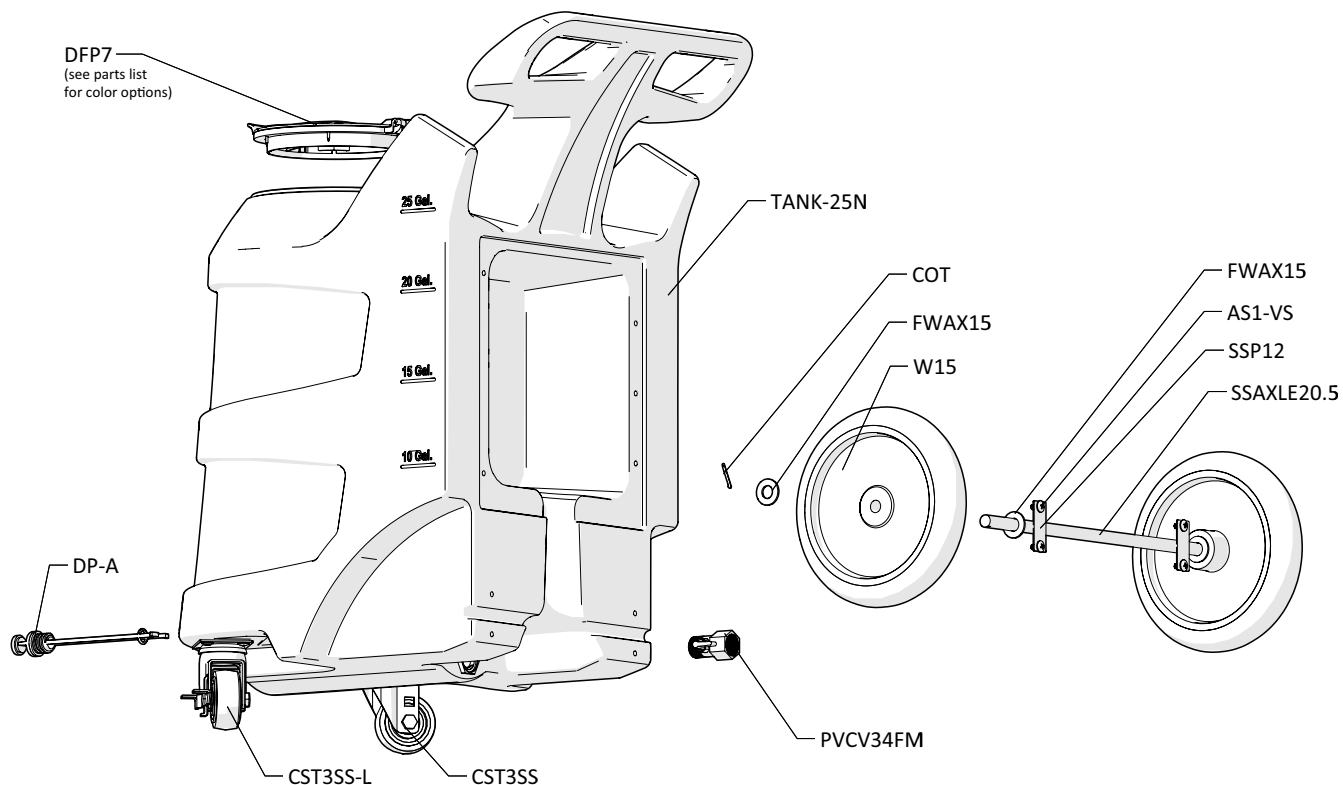

## SPRAY GUN ASSEMBLY ITEM NUMBER: SGA14

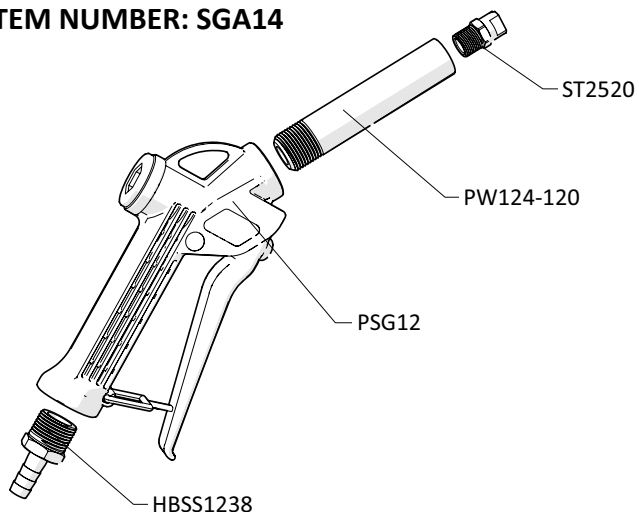

## DISCHARGE HOSE ASSEMBLY ITEM NUMBER: H38-30

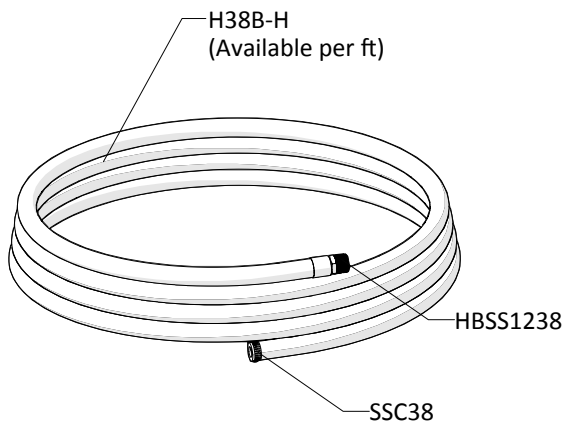

**READ ALL INSTRUCTIONS BEFORE OPERATING EQUIPMENT**

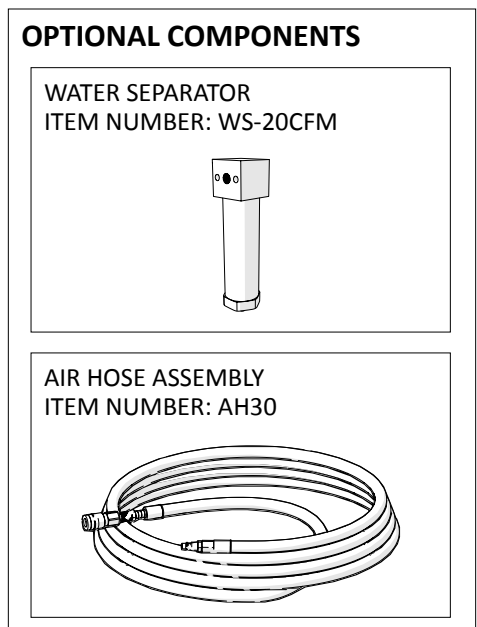
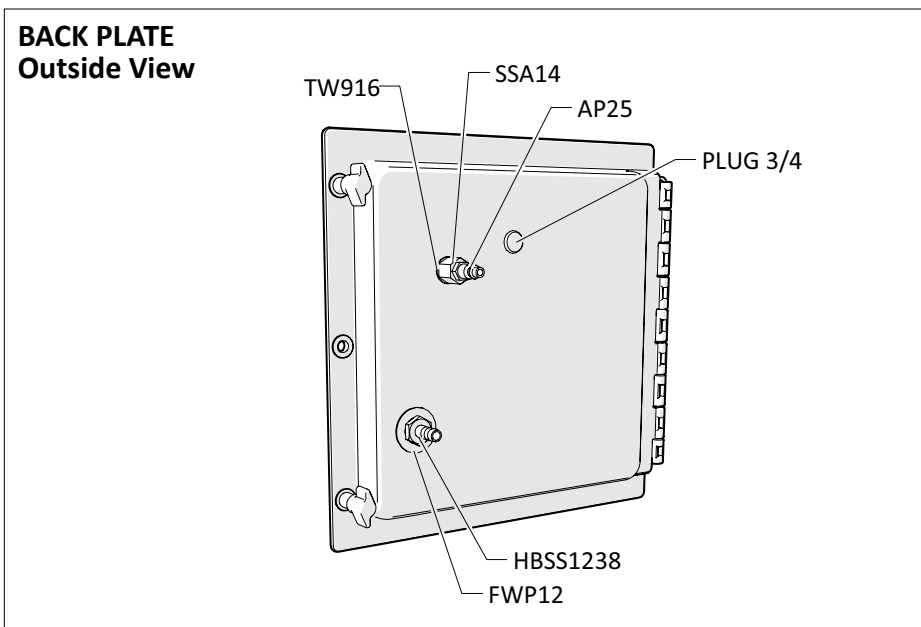
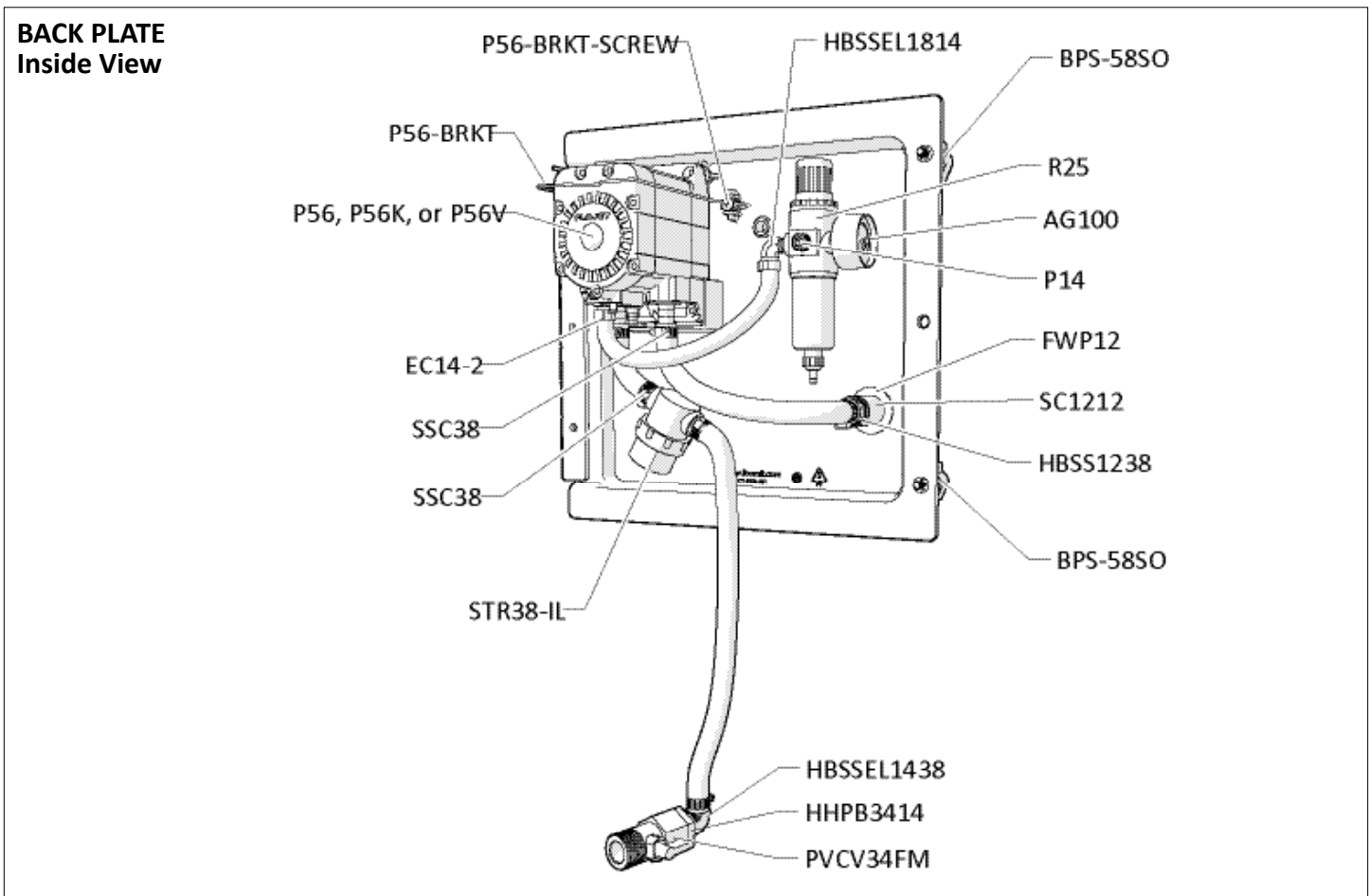

## READ ALL INSTRUCTIONS BEFORE OPERATING EQUIPMENT

ITEM NUMBER	DESCRIPTION
AG100	1.5 INCH DRY MODEL 20 DUAL SCALE GAUGE
AH30	30 ft Air Hose w/ Quick Connect Fittings
AP25	PLUG 1/4 NPTM AIR FITTING - BRASS
AS1-VS	1/4-20 X 1/2 PHIL TRUSS MACH SCREW 19-8 W/516 ORANGE VIBRASEAL PATCH
B8X58	8-15 X 5/8 inch PHIL FLAT TY-A 316 S.S.
BPS-58SO	Back Panel Screw - 5/8 inch with Stand Off
BPS-SSR	1/4 INCH PUSHNUT BOLT RETAINER STAINLESS STEEL
COT	1/8 X 1 COTTER PIN 18-8 S/S
CST3SS	3in S.S. SWIVEL CASTER WITHOUT LOCK
CST3SS-L	3in S.S. SWIVEL CASTER WITH LOCK
DFP7	7 INCH HINGED CAP ASSEMBLY - INCLUDES BLACK CAP, LID FLANGE AND HINGE PIN
<i>DFP7-C</i>	7 INCH FILL CAP POLYPRO BLACK
<i>DFP7-F</i>	7 INCH TANK LID FLANGE POLYPRO
<i>DFP7-PIN</i>	HINGE PIN FOR DFP7-C & DFP7-C
DFP7-C-BL	7 INCH FILL CAP POLYPRO BLUE PANTONE
DFP7-C-GN	7 INCH FILL CAP POLYPRO GREEN PANTONE
DFP7-C-RD	7 INCH FILL CAP POLYPRO RED PANTONE
DFP7-C-YL	7 INCH FILL CAP POLYPRO YELLOW PANTONE
DP-A	DRAIN PLUG ASSEMBLY FOR TANK-10N TANK-20N
<i>DP</i>	FRONT DRAIN PLUG FOR PORTABLE UNIT POLYPRO
<i>DP-G</i>	FKM SQUARE CUT DRAIN PLUG GASKET
DP-INSERT	304 STAINLESS DRAIN PLUG INSERT
EC12	OETIKER CLAMP 21.0-706R
EC14-2	OETIKER CLAMP 13.8
F38SS	STAINLESS 3/8 INCH FERRULE
FWAX15	FLAT AXLE WASHER
FWP12	7/8 ID X 1.5 OD X 0.05 THK SSFW
H14B-H	1/4 INCH BLUE HOSE - Available per ft
H38B-H	3/8 INCH BLUE HOSE - Available per ft
HBFSS1238	HOSE BARB 3/8 X FEMALE PIPE THREAD 1/2 IN STAINLESS STEEL
HBSS1238	STAINLESS HOSE BARB 1/2mpt X 3/8 barb Tariff 8479.90.9496
HBSEL1438	STAINLESS HOSE BARB ELBOW 1/4 INCH NPT X 3/8 HOSE BARB
HBSEL1814	304 STAINLESS ELBOW 1/8 INCH NPT X 1/4 INCH HOSE BARB
HHPB3414	HEX HEAD POLY REDUCER BUSHING 3/4 X 1/4
P14	COUNTERSUNK PLUG-HEXAGON 1/4

P56	5700 PUMP WITH SANTOPRENE SEALS - INCLUDES HOSE BARBS, AIR FITTING, AND AIR PORT
P56K	5700 PUMP WITH KALREZ SEALS - INCLUDES HOSE BARBS, AIR FITTING, AND AIR PORT
P56V	5700 PUMP WITH VITON SEALS - INCLUDES HOSE BARBS, AIR FITTING, AND AIR PORT
<i>20756103B</i>	Polypro G57 Air Port x HB Straight, w/ Viton o-ring
<i>HB14P</i>	1/4in BRASS HB AIR FITTING /G57/P56
<i>HB5638</i>	HOSE BARB FOR P56 PUMP
<i>HB5638K</i>	HOSE BARB FOR P56K PUMP
<i>HB5638V</i>	HOSE BARB FOR P56V PUMP
P56-BRKT	PUMP BRACKET- STAINLESS STEEL
P56-BRKT-SCREW	HI LO SCREW FOR RETAINING P56-BRKT
PLPF	PORTABLE FOAMER BACK PLATE W/ HINGE AND HOLES
PLPF-PIN	302 STAINLESS PORTABLE PLATE HINGE PIN
PLUG 3/4	TUBING PLUG 3/4 ( FITS 11/16 HOLE)
PSG12	Assembly with o-rings included/1/2in POLY SPRAY GUN W/ GRAY HNDL. & 316SS
<i>PSGORV</i>	PSG12 VITON O RING
PVCV34FM	PVC VALVE 3/4in FPT X 3/4in MPT
PW124-120	1/2in BLACK POLY PRO X 4in - SCH.120 - 1/2in MPTOE & 1/4in FPTOE
R25	AIR REGULATOR - SILVER COLOR - 1/4fpt TWO PORT 1/8fpt TWO PORT - INCLUDES FILTER AND BOWL
<i>AFR25</i>	AIR FILTER for R25
<i>ABR25</i>	METAL AIR BOWL for R25
S142058-VS	1/4-20 X 5/8 PHIL TRUSS MACHINE SCREW 18-8 W/#516 VIBRASEAL ORANGE PATCH
SC1212	S.S. COUPLER 1/2in BY 1/2in
SSA14	SS304 MALE/FEMALE ADAPTOR 1/4 NPT X 1/4 NPT
SSAXLE20.5	STAINLESS STEEL AXLE 20.5 INCHES LONG BY 5/8 INCH IN DIAMETER DRILLED AND BEVELED
SSC38	WORM GEAR CLAMP, S/S (.25-.63)
SSP12	STAINLESS STEEL AXLE PLATE - 2.5 inch X 1 inch - 2 HOLE
ST2520	VEEJET NOZZLE - BRASS 2520
STR38-IL	IN LINE STRAINER 3/8 BARB 20 MESH 304 STAINLESS EDPM GSKT
TANK-25N	30 GALLON NATURAL ROTOMOLDED TANK
TW916	1/2 INT TOOTH L/W 410SS
W15	NONMARKING WHEEL FOR PORTABLE UNITS
WS-20CFM	TSUNAMI WATER SEPARATOR 20 CFM