

---

# **USER MANUAL**

**MODEL NUMBER:  
FOG-IT6  
FG-NA-N130  
FG-NA-26SS  
AND RELATED ITEMS**

**Wall-Mounted Fog System**

---

**English (Original Instructions)**

---

## READ ALL INSTRUCTIONS BEFORE OPERATING EQUIPMENT

# WARNING



### Read this manual completely and understand the machine before interacting with it.

- Read all instructions before installing or operating unit.
- Always wear appropriate personal protective equipment (PPE) when operating or servicing unit.
- Always follow all chemical safety precautions and handling instructions provided by the chemical manufacturer and Material Safety Data Sheet (MSDS).
- Fogging with chemical products can be hazardous. Know the hazards of your chemical products prior to use. Wear appropriate personal protective equipment and follow all instructions and safety precautions in accordance with the MSDS for your chemical product.
- If this unit is modified or serviced with parts not listed in this manual, the unit may not operate correctly.
- Before performing any maintenance on this unit, disconnect the unit from the electrical power source and compressed air supply, and open the air purge valve (QFSOV38) to release any air pressure stored in the system.
- Do not exceed an incoming air pressure of 150 psi (10.3 bar).
- Do not exceed a fluid temperature of 100°F (37°C).
- Only use clean and dry air. Air must be filtered and free of moisture or pump life will be diminished. If needed, install a water separator (WS-20CFM) before unit.
- Do not use an air lubricator before the unit.
- Never use unit if it is damaged or leaking.
- Disconnect unit from electrical power source before servicing.

### PROTECT THE ENVIRONMENT

Please dispose of packaging materials, old machine components, and hazardous fluids in an environmentally safe way according to local waste disposal regulations.



Always remember to recycle.

Specifications and parts are subject to change without notice.

OPTIONS	
Control box	<b>Pump Seal Material</b>
	Santoprene ( <i>standard</i> )
	Viton ( <b>V</b> )
FOG-IT6	Kalrez ( <b>K</b> )
Add bold option codes to item number as shown. For standard options, no option code is needed. Examples: <ul style="list-style-type: none"> <li>• FOG-IT6 (standard unit with Santoprene pump seals)</li> <li>• FOG-IT6V (unit with Viton pump seals)</li> </ul>	
Nozzle assemblies	FG-NA-N130 FG-NA-26SS

## READ ALL INSTRUCTIONS BEFORE OPERATING EQUIPMENT

REQUIREMENTS		
	WITH FG-NA-N130 NOZZLES:	WITH FG-NA-26SS NOZZLES:
Compressed air requirements	At factory air pressure setting of 50 psi (3.4 bar): 2 cfm (56.6 l/min) for control box, plus 2.5 cfm (70.8 l/min) per nozzle  Maximum incoming air pressure: 150 psi (10.3 bar)	At factory air pressure setting of 50 psi (3.4 bar): 2 cfm (56.6 l/min) for control box, plus 5 cfm (142 l/min) per nozzle  Maximum incoming air pressure: 150 psi (10.3 bar)
Liquid temperature range	40-100°F (4.4-37°C)	
Electrical requirements	120 VAC at 60 Hz, 2 amps (GFCI protected outlet)	
Operating voltage	120 VAC	
Chemical compatibility	Chemical products used with this equipment must be formulated for this type of application and compatible with unit materials and pump seals. For more information on chemical compatibility, consult the manufacturer or MSDS for your product.	

SPECIFICATIONS		
	WITH FG-NA-N130 NOZZLES:	WITH FG-NA-26SS NOZZLES:
Power type	Compressed air, electricity	
Chemical pickup type	Draws from pre-mixed solution	
Number of products unit can draw from	One product	
Suction line length/diameter	8 ft. (2.4 m) hose with 3/8 in. (9.5 mm) inside diameter)	
Flow rate*	7.9 oz/min (0.23 l/min)	5.3 oz/min (0.16 l/min)
Pump seals	Santoprene, Viton, or Kalrez	
Nozzle construction	Polypropylene and kynar	Celcon, stainless steel, EPDM and nylon
Timer operation type	Delay on make single shot	
Droplet size	15 micron at 50 psi (3.4 bar)	35 micron at 50 psi (3.4 bar)
Coverage area	1 liter of solution will cover approximately 1000 cubic feet**	
Coverage pattern	Flat pattern with projection up to 10 ft. (3 m) from nozzle	Pattern up to 8 ft. (2.4 m) wide (side to side) and 3 ft. (0.9 m) thick (top to bottom), with projection up to 15 ft. (4.6 m) from nozzle
Number of nozzles***	1-20 nozzles per control box	1-12 nozzles per control box
Tubing/fitting sizes	Designed for use with 3/8 in. (9.5 mm) outside diameter tubing between control box and nozzle(s)	

\*Dilution rates and flow rates given are based on chemical with viscosity of water and factory air pressure settings.

\*\*Area covered and run time may vary based on humidity, air flow, and product used.

\*\*\*Number of nozzles is dependent upon air supply (see Compressed Air Requirements)

## READ ALL INSTRUCTIONS BEFORE OPERATING EQUIPMENT

### Installation Instructions

1. Remove all components from packaging.
2. Select an area to mount the control box.  
Note: The control box should be mounted to a vertical wall. We recommend mounting the control box at a height of 6 ft. (1.8 m) or less. The chemical suction line must reach the bottom of the chemical container. The bottom of the chemical container should not be positioned higher than the bottom of the control box.
3. Attach the control box mounting feet to the back of the control box, using the four screws provided in the parts package.
4. Mount the control box to the wall using the four screws and plastic anchors provided in the parts package.  
Note: To drill holes for the plastic anchors, use a 5/16 inch drill bit.
5. Install the air purge valve (QFSOV38) and tee fitting (QFT38) as shown in the diagram.

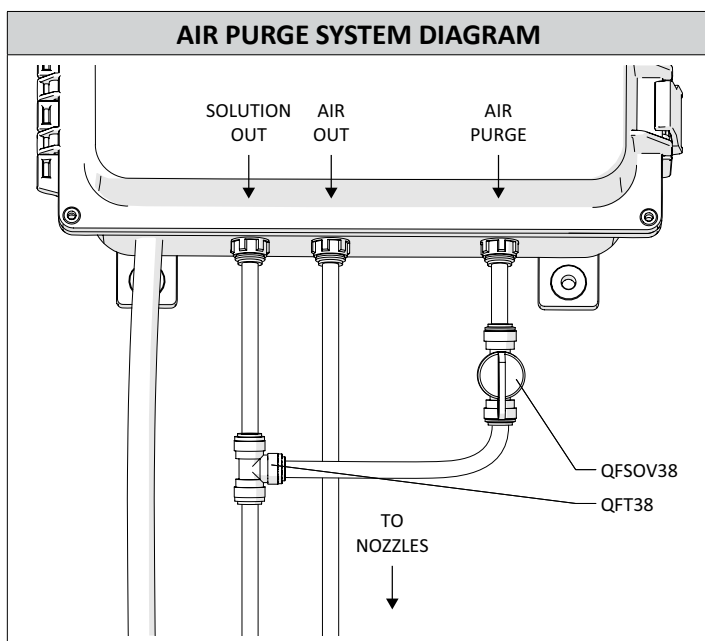

6. Mount the fog nozzle assembly (FG-NA-N130, FG-NA-26SS) in the desired location, using the included screws and plastic anchors. Repeat as needed for multiple nozzles.
7. Run tubing (H38CP) from the tee fitting (QFT38) to the solution inlet fitting on a nozzle assembly. Then run tubing from the solution outlet fitting on the original nozzle to the solution inlet fitting on the next nozzle. Repeat as needed for multiple nozzles.

8. Run tubing (H38CP) from the air outlet (QF1238) on the control box to the air inlet fitting on a nozzle assembly. Then run tubing from the air outlet fitting on the original nozzle to the air inlet fitting on the next nozzle. Repeat as needed for multiple nozzles.  
Note: The air and solution lines must be routed to the appropriate fittings (as labeled), or the fog quality of the unit will be negatively impacted. Make sure to insert the tubing all the way into the fittings to ensure proper connection.
9. When you reach the last nozzle, either plug the air and solution outlet fittings, or loop the air and solution lines from the last nozzle back into the system.  
Note: Depending on your configuration, plugs (QFP38), additional tee fittings (QFT38) and/or additional tubing (H38CP) may be required to complete the installation.
10. With the air inlet valve (HV60-H) in the closed position, connect a compressed air line to the air inlet fitting (SSE12). The air inlet fitting is 1/2 in. FPT.
11. Set the timer (TRDU120) for the desired delay time and run time, as described in the timer adjustment instructions.

### TIMER ADJUSTMENT INSTRUCTIONS

The TRDU120 is a multifunction timer.

#### To set the timer:

1. The five “MODE” switches (A-E) in the bottom left corner set the timer function. For fogging applications, switch A and switch D should be ON, and the other switches (B, C, and E) should be OFF. This puts the timer in Dual Mode, with the 1st Delay functioning as a delay time, and the 2nd Delay functioning as a single-shot run time.
2. The remaining three switches in the bottom row set the time interval. One switch lets you choose MIN (minutes) or SEC (seconds). The other two switches let you select a multiplier (x0.1, x1, x100), which can increase or reduce the total active time.
3. The switches in the upper column control the active time. In Dual Mode, the top 5 switches control the 1st Delay (delay time), and the lower 5 switches control the 2nd Delay (run time). The active time for each function is equal to the total of the numbers next to any of these switches that are ON, times the selected multiplier.

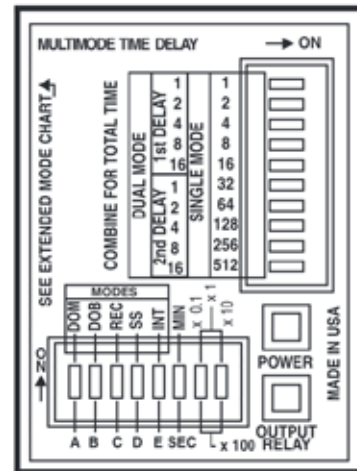

## READ ALL INSTRUCTIONS BEFORE OPERATING EQUIPMENT

12. With the power switch (TS2, TS2PLATE, TSBT12) in the OFF position, plug the unit into a GFCI protected 120 VAC power outlet.
13. Follow all instructions from chemical manufacturer. Place the chemical suction line into a container of pre-mixed chemical solution.

### Operation Instructions

Fogging with chemical products can be hazardous. Know the hazards of your chemical products prior to use. Wear appropriate personal protective equipment and follow all instructions and safety precautions in accordance with the MSDS for your chemical product.

1. Prepare the area to be fogged.
2. Verify the delay time and run time settings on the timer (see Timer Adjustment Instructions).
3. Make sure the air inlet valve (HV60-H) is open, and the air purge valve (QFSOV38) is closed.
4. Turn the power switch (TS2, TS2PLATE, TSBT12) to the ON position.
5. To activate the unit, push the green button (BUT78GR). The unit will begin cycling through the delay and run time intervals set on the timer, beginning with the delay time.
6. At the end of the run time, the unit will shut off. Observe appropriate safety precautions when reentering the area, in accordance with the MSDS for your chemical product.
7. Turn the power switch (TS2, TS2PLATE, TSBT12) OFF to prevent unwanted activation of the unit
8. With the air inlet valve (HV60-H) in the open position, open the air purge valve (QFSOV38) to clear any solution from the lines. Close the air purge valve (QFSOV38) after all solution has been cleared from the system.

### Maintenance Instructions

To keep your fog unit operating properly, periodically perform the following maintenance procedures:

Note: Before performing any maintenance, disconnect the unit from the electrical power source and compressed air supply, and open the air purge valve (QFSOV38) to release any air pressure stored in the system.

- Inspect the pump (P56/P56K/P56V) for wear and leaks.
- Inspect all hoses for leaks or excessive wear. Make sure all hose clamps and push-fittings are in good condition and properly secured.
- Check the chemical suction line and strainer for debris and clean as needed.
- Drain your air compressor tank on a regular basis to help extend pump life. An air source with a high moisture content will accelerate pump wear. Note: If your air source has a high moisture content, you may wish to install a water separator (WS-20CFM) before the unit.

### Troubleshooting Instructions

- If air passes through the pump (P56/P56K/P56V) without cycling, the pump needs to be replaced.
- Check the chemical suction line and strainer for debris or damage. Clean or replace as needed. To prevent damage to the unit, the strainer (STR14) must always be used.

**READ ALL INSTRUCTIONS BEFORE OPERATING EQUIPMENT**

**CONTROL BOX ASSEMBLY  
Inside View**

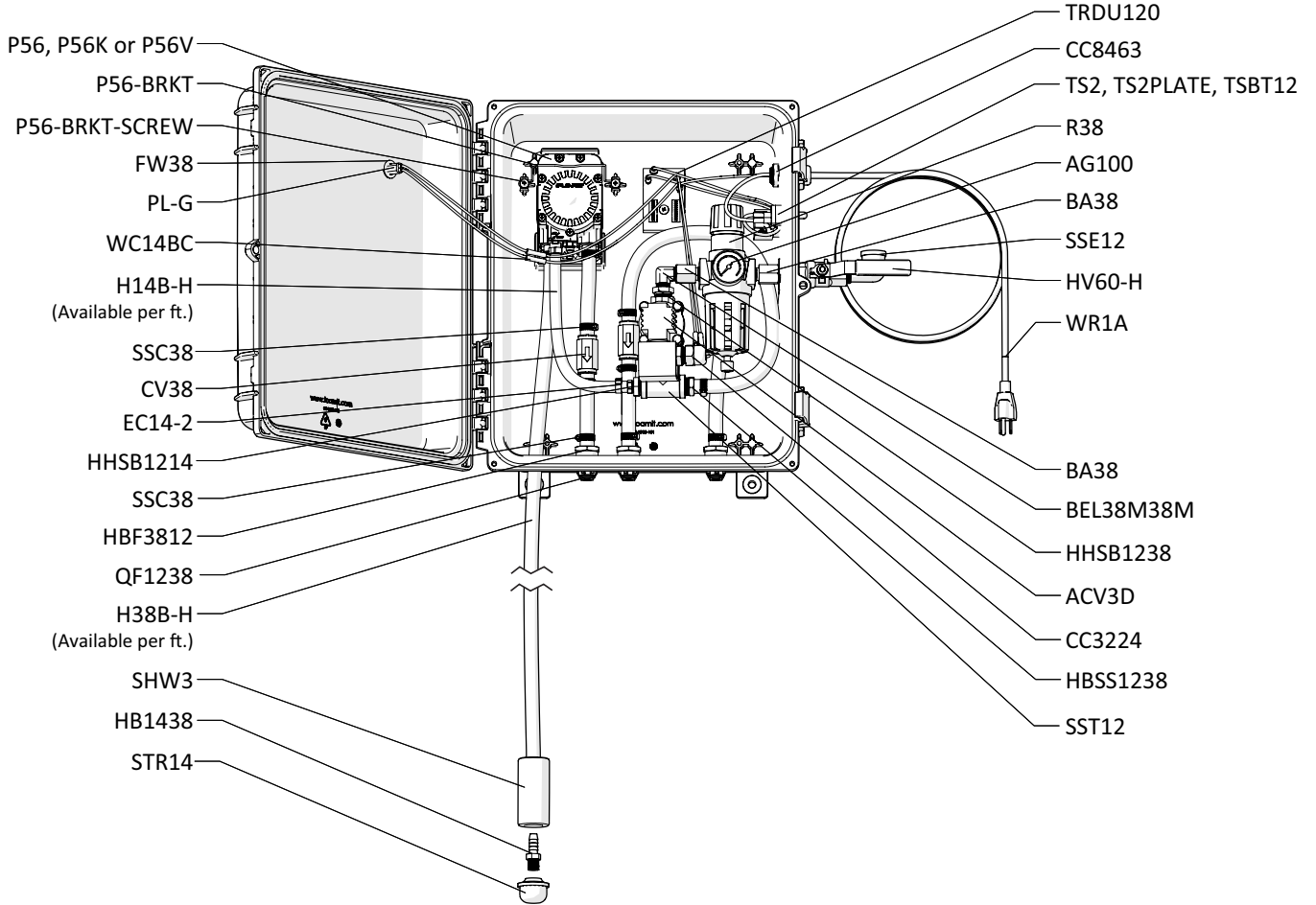

**CONTROL BOX ASSEMBLY  
Outside View**

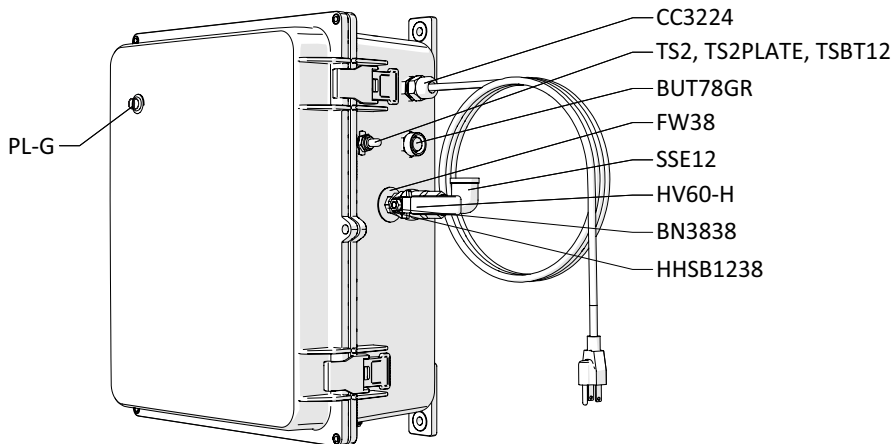

**OPTIONAL COMPONENT**

WATER SEPARATOR  
Item Number: WS-20CFM

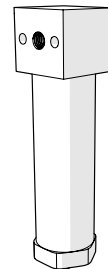

**READ ALL INSTRUCTIONS BEFORE OPERATING EQUIPMENT**

**NOZZLE ASSEMBLY**  
**Item Number: FG-NA-N130**

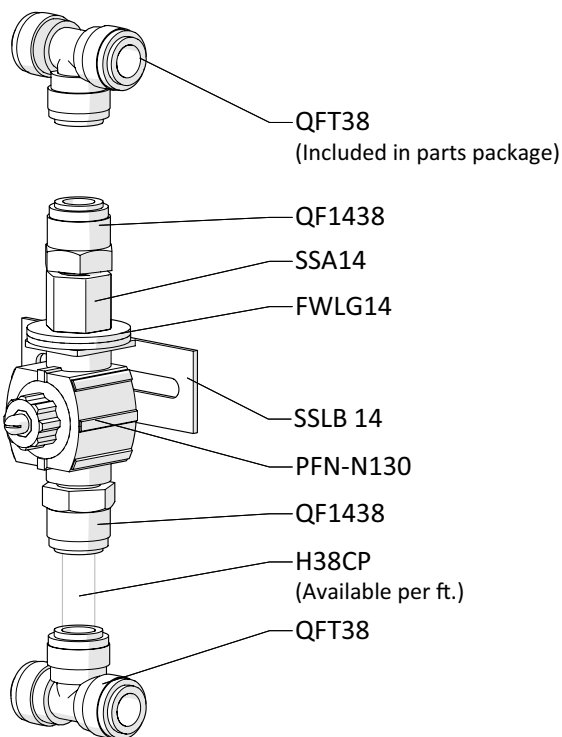

**NOZZLE ASSEMBLY**  
**Item Number: FG-NA-26SS or FOG-IT6-NP**

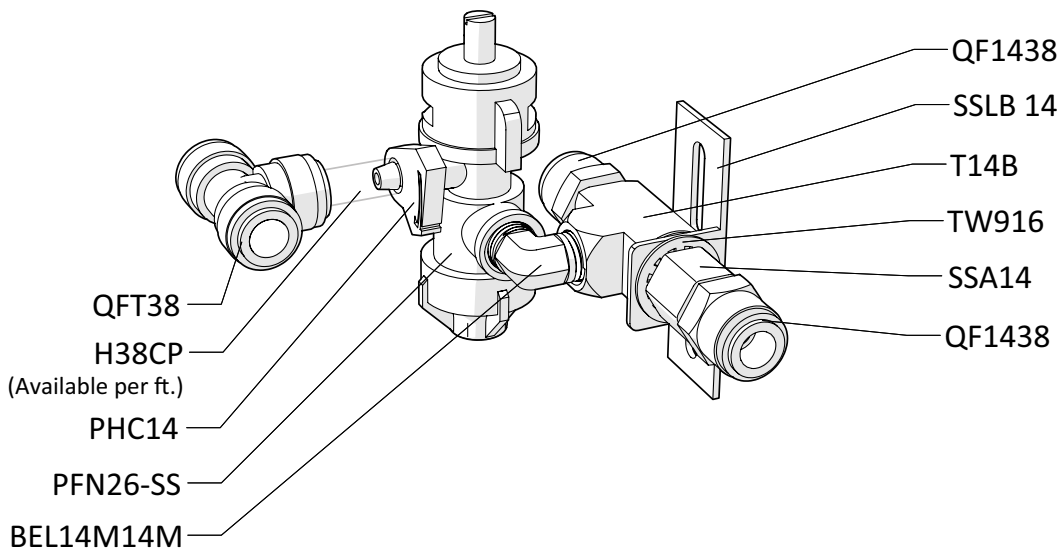

## READ ALL INSTRUCTIONS BEFORE OPERATING EQUIPMENT

ITEM NUMBER	DESCRIPTION
ACV3D	1/2 DEMA AIR SOLENOID, BRASS - 120v - 31gpm
AG100	1.5 INCH DRY MODEL 20 DUAL SCALE GAUGE
B103225	10-32 X 1/4in PHIL MACH SCREW 18-8
BA38	3/8 MPT X 3/8 FPT ADAPTOR
BEL14M14M	BRASS ELBOW 1/4in MPT X 1/4in MPT
BEL38M38M	BRASS ELBOW 3/8in MPT X 3/8in MPT
BN3838	BRASS HEX NIPPLE 3/8in X 3/8in
BUT78GR	PB OPR NO CB
CC3224	LTC BLACK 1/2 NPT
CC8463	1/2in NPT BLACK LOCKNUT
CV38	PVC CHECK VALVE 3/8 BARBS - SS SPRING
EC14-2	OETIKER CLAMP 13.8
FW38	.687 ID X 1-1/2 OD X .07 TK FLATWASHER (5/8) 18-8
FWLG14	.569 ID X 1.28 OD X .08 THICK FLAT WASHER SS 18-8
H14B-H	1/4 INCH BLUE HOSE- GOODYEAR HORIZON - Available per ft.
H38B-H	3/8 INCH BLUE GOODYEAR HORIZON HOSE - Available per ft.
H38CP	3/8 IN OD POLYETHYLENE TUBING - NATURAL - Available per ft.
HB1438	1/4in MPT X 3/8in HOSE BARB (PLASTIC)
HBB1414	BRASS 1/4 X 1/4 HOSE BARB
HBF3812	HOSE BARB 3/8 X FEMALE PIPE THREAD 1/2 IN
HBSS1238	STAINLESS HOSE BARB 1/2mpt X 3/8 barb
HBSSEL1438	STAINLESS HOSE BARB ELBOW 1/4 INCH NPT X 3/8 HOSE BARB
HHBB1418	HEX HEAD BRASS BUSHING 1/4in X 1/8in
HHSB1214	HEX HEAD S.S. REDUCER BUSHING 1/2 X 1/4
HHSB1238	HEX HEAD S.S. REDUCER BUSHING 1/2in X 3/8
HV60-H	1/2" S.S. BALL VALVE W/ STRAIGHT HANDLE W/O WELD
P56	5700 PUMP WITH SANTOPRENE SEALS - INCLUDES HOSE BARBS, AIR FITTING, AND AIR PORT
P56K	5700 PUMP WITH KALREZ SEALS - INCLUDES HOSE BARBS, AIR FITTING, AND AIR PORT
P56V	5700 PUMP WITH VITON SEALS - INCLUDES HOSE BARBS, AIR FITTING, AND AIR PORT
20756103B	Polypro G57 Air Port x HB Straight, w/ Viton o-ring
HB14P	1/4in BRASS HB AIR FITTING /G57/P56
HB5638	HOSE BARB FOR P56 PUMP
HB5638K	HOSE BARB FOR P56K PUMP
HB5638V	HOSE BARB FOR P56V PUMP
P56-BRKT	PUMP BRACKET- STAINLESS STEEL
P56-BRKT-SCREW	HI LO SCREW FOR RETAINING P56-BRKT
PB16138	POLYPROPYLENE CONTROL BOX - WORKING DIMS 16x13x8 - PUMP MOUNT

PB16138-GSKT	NEOPRENE GASKET 0.220 INCH ROUND CORD STOCK
PB16138-LATCH	LATCH FOR PB16138
PB16138-PIN	STAINLESS STEEL HINGE PIN FOR CONTROL BOX PB16138 - 1/8 x 4 3/4 x 1/2inches
PBFT-PP	MOUNTING FEET FOR POLYBOX - PB16138 - POLYPROPYLENE
PFN26-SS	PNEUMATIC FOG NOZZLE WITH STAINLESS STEEL TIP - HIGH FLOW
PFN-N130	Pneumatic Fog Nozzle(1/4QMJ+SUQF-N130 ASSEMBLED) - Polypropylene and KYNAR
PHC14	BLACK POLY HOSE CLAMP
PL16138	CONTROL BOX LID - POLYPROPYLENE - 16x13x8 - HINGED LOCKABLE LID
PL-G	GREEN PILOT LIGHT - MC GILL
QF1238	MALE CON. 3/8in TUBE X 1/2in MPT - POLYPROPYLENE
QF1438	MALE CON. 3/8in TUBE X 1/4in MPT - POLYPROPYLENE
QFSOV38	SHUT OFF VALVE 3/8in TUBE POLYPROPYLENE
QFT38	UNION TEE 3/8in TUBE POLYPROPYLENE
R38	CFDR60-3NG FILTER, REG 3/8in
S1034FHL	10 X 3/4 PHIL FLAT HI-LO THRD SCREW 18-8
SHW3	3in LONG COATED WEIGHT
SN1212	1/2in HEX STAINLESS STEEL NIPPLE
SSA14	SS304 MALE/FEMALE ADAPTOR 1/4 NPT X 1/4 NPT
SSC38	WORM GEAR CLAMP, S/S (.25-.63)
SSE12	STREET ELBOW 1/2in - 316 S.S.
SSLB 14	14GA SS BRACKETS W/SLOTS
SST12	1/2in FPT 304 S.S. TEE
STR14	40 MESH SUCTION LINE STRAINER 1/4 MNPT
T14B	FEMALE BRASS TEE 1/4in
TRDU120	120 VOLT MULTI-FUNCTION TIME RELAY
TRS11	11 PIN MAGNAL SOCKET
TS2	TOGGLE SWITCH SPST
TS2PLATE	ON/OFF SWITCH PLATE
TSBT12	TOGGLE SWITCH BOOT
TW916	1/2 INT TOOTH L/W 410SS
WC14BC	BUTT CONNECTOR
WC14FRK	14-16 - INSULATED NARROW FORK TERM. CONNECTOR
WCB14F	14-16 - 1/4 FEM INSULATED CONNECTOR
WCB14FY	10-12 - 1/4in FEMALE INSULATED CONNECTOR
WMS14	14 X 1 1/4 HEX W/H SMS SLOTT, S/S
WMS14A	5/16 X 1 1/2 STRAIGHT PLASTIC ANCHOR
WR1A	18/3 SJOOW 90 BLACK N.A. W/ 5-15P & 7in ROJ
WS-20CFM	TSUNAMI WATER SEPARATOR/AIR DRYER 20 CFM