



FOAMiit

product catalog

Why FOAMit?

FOAMit builds innovative cleaning equipment for chemical management and application. Our customers and end users know we build easy-to-use and easy-to-maintain products, backed by exceptional customer support.

Founded in the 1980's by Dan Jacques, FOAMit has built a reputation on quality products and innovation. Our engineering team doesn't rest on good enough. We are dedicated to improving our current products while innovating for the next generation of products.

As a value-driven company, we care about more than the bottom-line, we're all about making "it" better for you. When you work with FOAMit you have an ally in the fight for clean.

Our top priority is to our customers and meeting their needs. Need a chemistry application unit that you can't find in this catalog? Our tech and product teams can partner with you to create a custom solution.









Ready to order?

Reach out and one of our friendly experts will be happy to make your day.

800 567 5420
sales@foamit.com



Contents

 Portables	5
Pre-Mix.....	6
Concentrate	7
Fog + Mist.....	8
Battery.....	9
 Wall Mounted	11
Pre-Mix.....	12
Concentrate.....	13
Fog + Mist	14
Central Systems	15
Doorway	16
 Footwear Sanitation	19
Air Powered	20
Foot Powered.....	21
 Chemical Management.....	23
Wall Transfer	24
Wall Mixing.....	26
Portable Transfer	27
Jugs.....	28
Locking Caps	30
Racks + Stands.....	31
 Pump-Ups.....	33
Manual Powered.....	34
Dual Powered.....	35
Drain Foaming.....	36
 Attachments.....	39
Drain Foam	40
Belt Foam Bar	41
 Innovations	43
Drum Rinse.....	44
Flooded Suction Tank.....	45
 Color Options	47



Portable Units

Pre-Mix - p.6
Concentrate - p.7
Fog + Mist - p.8
Battery - p.9

Portables

Trusted workhorses since their introduction in the 1980's, our portables take your chemistry where it's needed. Each unit is highly configurable with cap and hose color options, wand selection, and various hose lengths available. Additionally, choose pump seals for maximum chemical compatibility available in Viton, Kalrez, or Santoprene.

From the front facing drain and built-in hose storage, to the quick-change pump and modular hinged back plate – our innovative portable units are designed to be easy-to-use and maintain.

Foam, Spray, Gel, Smart Foam, and Fog + Mist configurations available.



foam



spray



gel



smart



fog + mist

The Good Stuff

- **Easy to use, easy to maintain**
Designed for portability, efficiency, and hassle-free maintenance. Our quick-change pump and tool-free, hinged access plate reduce downtime when a repair is needed.
- **Natural tank**
See chemical volume levels at a glance.
- **Configure with color**
Lids and hoses come in a variety of colors to match your chemical management systems and quickly tell units apart.



FI-30N



Pre-Mix

Color options available - p. 47

5 Gallon (18.9 Liter)



FI-5N	● Air powered foam
SP-5N	● Air powered spray
GI-5N	● Air powered gel
FI-5N-SM	● Air powered smart foam

10 Gallon (37.9 Liter)



FI-10N	● Air powered foam
SP-10N	● Air powered spray
GI-10N	● Air powered gel
FI-10N-SM	● Air powered smart foam

20 Gallon (75.7 Liter)



FI-20N	● Air powered foam
SP-20N	● Air powered spray
GI-20N	● Air powered gel
FI-20N-SM	● Air powered smart foam

25 Gallon (94.6 Liter)



FI-25N	● Air powered foam
SP-25N	● Air powered spray
GI-25N	● Air powered gel
FI-25N-SM	● Air powered smart foam

30 Gallon (113.6 Liter)



FI-30N	● Air powered foam
SP-30N	● Air powered spray
GI-30N	● Air powered gel
GI-30N-AM	● Air powered gel - with air motor
FI-30N-SM	● Air powered smart foam

50 Gallon (189.3 Liter)



FI-50N	● Air powered foam
FI-50NT-HV	● Air powered high volume foam
SP-50N	● Air powered spray
FI-50N-SM	● Air powered smart foam

Concentrate

Color options available - p. 47

Our portable concentrate units dilute chemistry on the fly and ship with a variety of metering tips to meet your dilution rate. Each unit contains a 15- gallon water reservoir and holds two FOAMit chemical jugs (2.5-gallon and 5-gallon options available, see page 28-29) or use your own chemical containers. Units available in foam, spray, and dual function foam + spray.



15 Gallon (56.8 Liter)

FI-CN-15N	● Air powered foam
FI-CN-15N-2P	● Air powered foam - for 2 part products



FOAMit jug options — page 28-29





Fog + Mist

Color options available - p. 47



10 Gallon (37.9 Liter)

FG-10N-2	● Air powered fog - two nozzles on unit handle
FG-10N-2-TM	● Air powered fog - two nozzles on unit handle - with timer



10 Gallon (37.9 Liter)

FG-10N-3	● Air powered fog - three nozzles on telescoping mast
FG-10N-3-TM	● Air powered fog - three nozzles on telescoping mast - with timer



20 Gallon (75.7 Liter)

FG-20N-2	● Air powered fog - two nozzles on unit handle
FG-20N-2-TM	● Air powered fog - two nozzles on unit handle - with timer



Pictured: FG-10N-2



20 Gallon (75.7 Liter)

FG-20N-3	● Air powered fog - three nozzles on telescoping mast
FG-20N-3-TM	● Air powered fog - three nozzles on telescoping mast - with timer

Battery

Color options available - p. 47

Our battery powered portable units provide customers with quality chemical output no matter the location. Available in our lithium-ion battery powered Equip Series units (available on portable units from 5 to 30 gallons).

Take these units anywhere foam or sanitizer is needed. Equip Series units have a swappable battery that can be replaced on the fly to keep working.



5 Gallon (18.9 Liter)

FI-BP-5N	● Li-ion battery powered foam
SP-BP-5N	● Li-ion battery powered spray



10 Gallon (37.9 Liter)

FI-BP-15N	● Li-ion battery powered foam
SP-BP-15N	● Li-ion battery powered spray



20 Gallon (75.7 Liter)

FI-BP-20N	● Li-ion battery powered foam
SP-BP-20N	● Li-ion battery powered spray



see more details



25 Gallon (94.6 Liter)

FI-BP-25N	● Li-ion battery powered foam
SP-BP-25N	● Li-ion battery powered spray



30 Gallon (113.6 Liter)

FI-BP-30N	● Li-ion battery powered foam
SP-BP-30N	● Li-ion battery powered spray





Wall Mounted Units



- Pre-Mix - p.12
- Concentrate - p.13
- Fog + Mist - p.14
- Central Systems - p.15
- Doorway - p.16

Wall Mounted

Wall units come in a variety of configurations and uses. Whatever your need is, chances are we have a wall unit to meet it. Available in foam, spray, fog, mist, and dual function units for pre-mix or concentrate with configurable hose color and lengths. All wall units can be fitted with a lock to protect internal components.

Drop-stations for central systems are wall units that pull chemistry from a secure location at your facility. These are also available in foam, spray, fog, mist, and dual functions and can be configured for hose color and length.

Wall-mounted doorway foaming units protect transition zones. Foam clings to wheels and footwear as they pass through entrances providing a robust tool in the fight against cross-contamination.



foam



spray



fog + mist

The Good Stuff

- **Flexible configurations**
Foam, spray, fog, mist, or dual function options with customizable hose colors and lengths to suit your needs.
- **Centralized control**
Drop-stations draw from secure central systems, ensuring efficient chemical distribution.
- **Entryway protection.**
Doorway foam units create a strong barrier, preventing cross-contamination at entrances.



FI-WC-2P

Pre-Mix

Color options available - p. 47

Foam Pre-Mix Twin Line

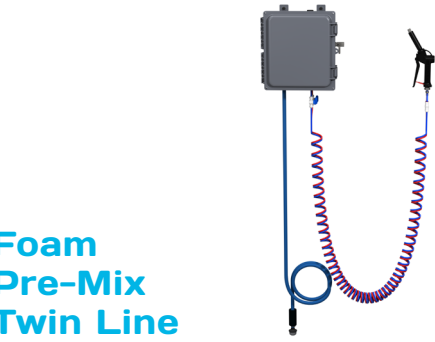

FI-TL	● Air powered foam - twin line
-------	--------------------------------

Foam Pre-Mix



FI-WALL	● Air powered foam
---------	--------------------

Spray Pre-Mix



SP-WALL	● Air powered spray
---------	---------------------

Foam Pre-Mix Poly Fittings



FI-WALL-AP	● Air powered foam - all poly fittings
FI-WALL-AP-2P	● Air powered foam - all poly fittings - 2 product selector

Spray Pre-Mix Poly Fittings



SP-WALL-AP	● Air powered spray - all poly fittings
------------	---

Concentrate

Color options available - p. 47

Wall mounted concentrate units ensure consistent and reliable chemistry application. A water regulator inside the unit keeps dilution rates consistent, regardless of changes with incoming water pressure. Don't let your chemistry take blame for problems caused by imprecise equipment.

When consistent performance counts, choose a concentrate unit that can deliver.

Foam Spray Conc.



FISP-WC	● Air powered foam and spray
---------	------------------------------

Spray Concentrate



SP-WC	● Air powered spray
-------	---------------------

Foam Concentrate



FI-WC	● Air powered foam
-------	--------------------

Foam Concentrate



FI-WC-2P	● Air powered foam - 2 product injector
----------	---

Foam High Conc. Poly Fittings



FI-WC-11AP	● Air powered foam - all poly fittings
FI-WC-11AP2	● Air powered foam - all poly fittings - 2 product injector

Spray High Conc. Poly Fittings



SP-WC-11AP	● Air powered spray - all poly fittings
------------	---



Fog + Mist

Color options available - p. 47

Originally designed for dumpster odor control, these units can also be used for dust suppression, sanitizing, humidification, and pesticide application.

Each wall-mounted box has a programmable repeat cycle timer. The FOG-IT6 / MU-6 can be configured for 12 nozzles (35 micron droplet size) to 20 nozzles (15 micron droplets) per box.

Talk with your salesperson to see which units and nozzles would work best for your application process.

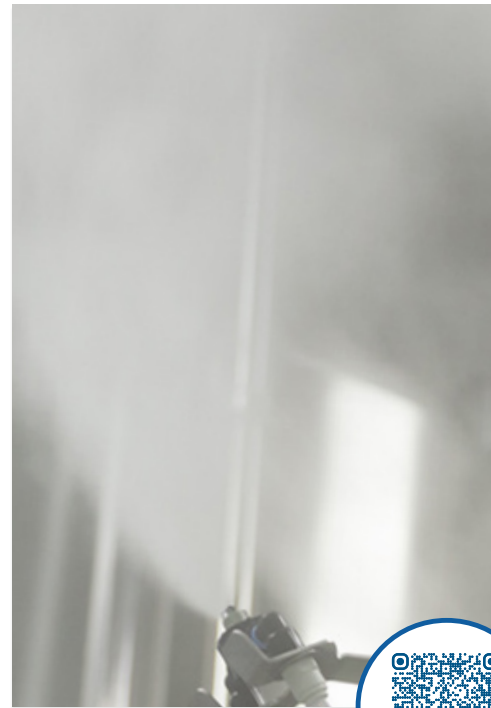

see more details



Pre-Mix

FOG-IT-DS	● Electric powered fog - with timer
-----------	-------------------------------------

Pre-Mix

FOG-IT6	● Air and electric powered fog
MU-6	● Air and electric powered mist

Central Systems

Color options available - p. 47

Reduce complexity while saving labor and time. Central systems deliver ready-to-use chemistry throughout a facility, pumped from one, secure location. Our systems are highly customizable – mix and match drop station functions to get exactly what you need, where you need it.

Contact your equipment sales representative to learn more about which drop-stations, pumps, and proportioners fit your needs.

Foam Station

FI-STATION	● Air powered foam
------------	--------------------

Twin-Line Foam System

CFS-TL	● Air powered foam - twin line
--------	--------------------------------

Dual Foam Station

FI-STDF	● Air powered foam
---------	--------------------

Foam and Spray Station

FI-STSAN	● Air powered foam and spray
----------	------------------------------

Doorway Foam Station

GK2T	● Electric powered foam
GK2T24	● Electric powered foam - 24 VAC
GK5T	● Electric powered foam - twin line discharge

Doorway Pump

GK1T	● Air powered foam
------	--------------------

Doorway Nozzle

GK6T	● Air powered foam - single line
------	----------------------------------

Twin-line Doorway Nozzle

GK7T	● Air powered foam - twin line
------	--------------------------------



Doorway

Busy wheels and boots track contaminants into sensitive locations without a proper shield. Protect your facility from unwanted hitchhikers with our doorway defenders.

Configurable to your specific entryway's needs (see nozzle illustrations), our units puts chemistry where it needs to be. Set the repeat cycle timer for foam application at the right time, every time.



see more details



Single-Line Pre-Mix

DS1	● Air and electric powered doorway foam
-----	---



Single-Line Concentrate

DS3	● Air and electric powered doorway foam
-----	---



Twin-Line Concentrate

DS4	● Air and electric powered doorway foam
DS4-2P	● Air and electric powered doorway foam - two product injector



Twin-Line Pre-Mix

DS5	● Air and electric powered doorway foam - one nozzle
DS5-2	● Air and electric powered doorway foam - two nozzle
DS5-3	● Air and electric powered doorway foam - three nozzle

One nozzle

Coverage area –
Up to 9 x 5 ft. (2.7 x 1.5 m)

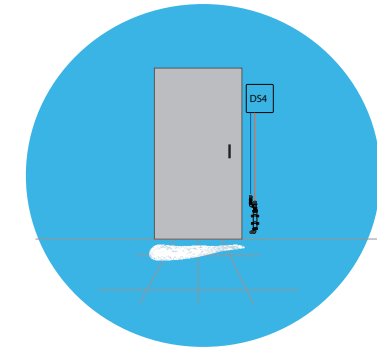

Two nozzles

Coverage area –
Up to 8 x 4 ft. (2.4 x 1.2 m)
at each nozzle

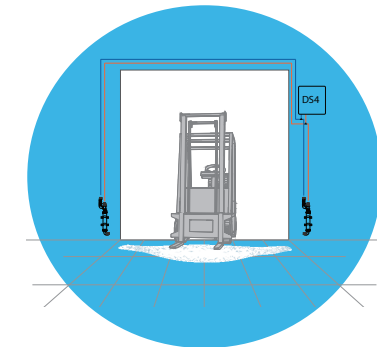

Three nozzles

Coverage area –
Up to 6 x 3 ft. (1.8 x 0.9 m)
at each nozzle

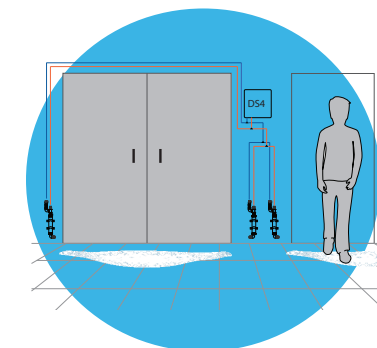



Footwear Sanitation

Air Powered - p.20
Foot Powered - p.21

Footwear Sanitation

Footwear sanitation is important for compliance and quality. We offer footwear systems that connect to compressed air (SS2, SS3) or work with the power of the human step with no utilities required (SS4).

Our single-foot units (SS2 + SS4) are configurable with a standalone handle or a boot scrubber with handle. Our walk-through sanitation unit (SS3) applies chemistry to both soles evenly, perfect for high traffic transition zones.

All footwear sanitation units are compatible with alcohol- and quat-based sanitation chemistry.



spray

The Good Stuff

- **Easy to use, easy to maintain**
Just step and go; sanitizer is evenly applied to footwear. Collection basin is easy to access or swap out for cleaning when a repair is needed.
- **Low moisture**
Helps keep moisture out of unwanted areas while still providing an effective sanitation on your shoe sole
- **Transition zones**
Effective sanitation in high traffic entryways or transition zones

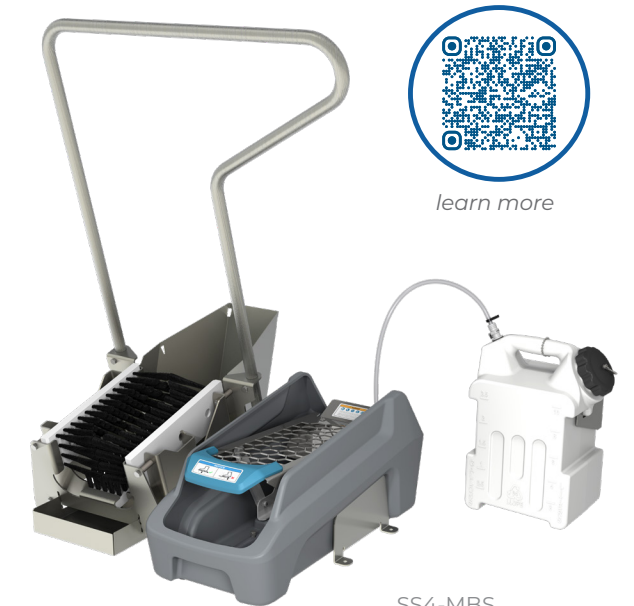

SS4-MBS



Air Powered



SS2

SS2 | Air powered footwear sanitizer



SS2-BSH

SS2-BSH | SS2 and base with handle



SS2-FMH

SS2-FMH | SS2 and floor mounted handle



SS2-MBS

SS2-MBS | SS2 and manual boot scrubber



SS3

SS3 | Walk through footwear sanitizer

Foot Powered



SS4

SS4 | Airless footwear sanitizer

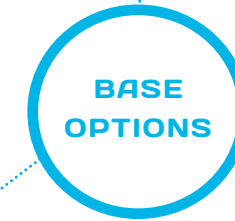

SS4-BSH

SS4-BSH | SS4 and base with handle



SS4-MBS

SS4-MBS | SS4 and manual boot scrubber



MBS

MBS | Manual boot scrubber with straight handle



MBS-C

MBS-C | Manual boot scrubber with combo handle



Chemical Management

Wall Transfer - p.24
Wall Mixing - p.26
Portable Transfer - p.27
Jugs - p.28
Locking Caps - p.30
Racks + Stands - p.31

Chemical Management

Chemical jugs, racks, stands, and transfer units make chemical storage and transportation secure and easy.

Chemical jugs come in a variety of cap and jug colors with options for locking caps, venting, and chemical pick-up lines. Choose between 2.5 and 5 gallon jugs.

Portable transfer units bring large quantities of chemistry to locations throughout a facility, available in three sizes and three wand options.

Wall chemical transfer units (TU and CTX) are easy to use when pumping from bulk drums to jugs or portable units.

Each facility has unique chemical management challenges, so reach out to us to learn more about options to meet your needs.

The Good Stuff

- **Secure and easy**
Chemical jugs, racks, stands, and transfer units make chemical storage and transportation secure and easy.
 - **Durable and functional**
Designed to handle a wide range of uses, whether stationary or on the move.
 - **Configure to your needs**
Chemical management can be challenging. Customize your unit to suit your facility's needs and enjoy peace of mind.
-



2.5 and 5 gallon jug



Wall Transfer



Configurations

CT	Pump seal material	Operating type	5
	Santoprene (1)	Manual air button (A)	
	Viton (2)	Timer and solenoid valve (D)	
	Kalrez (5)		

Examples:

- CT1A5 - Single product transfer unit with Santoprene pump seals and manual air button
- CT2D5 - Single product transfer unit with Viton pump seals and timer and solenoid valve
- CT5A5 - Single product transfer unit with Kalrez pump seals and manual air button

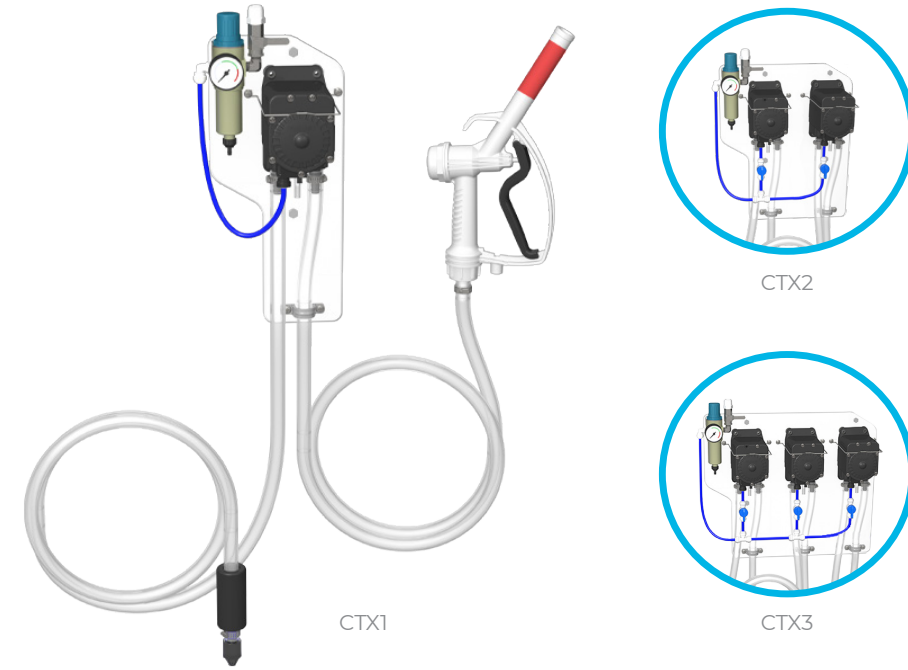

Configure up to five pumps

CTX	Number of pumps	Pump seal material
	One (1)	Santoprene (S)
	Two (2)	Viton (V)
	Three (3)	Kalrez (K)
	Four (4)	
	Five (5)	

Examples:

- CTX1K - Unit for one product; one pump Kalrez pump seals
- CTX2VK - Unit for two products; one pump Viton pump seals, one pump Kalrez pump seals
- CTX3V - Three products; all three pumps Viton pump seals
- CTX4SSKK - Four products; two pumps Santoprene pump seals, two pumps Kalrez seals
- CTX5 - Five products; all five pumps Santoprene pump seals

Note: For Santoprene only units, no option code needed.



Wall Mixing

Color options available - p. 47



Mixing Station

MS-2P	Water operated - for 2-part concentrate products
-------	--

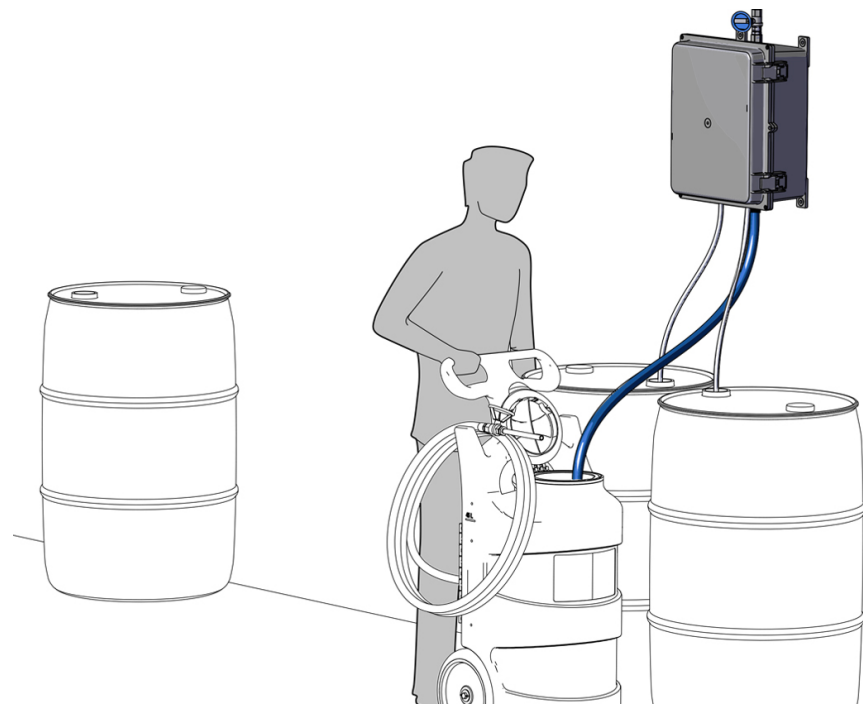

Portable Transfer

Color options available - p. 47



20 Gallon (75.7 Liter)

TU-20N-PFG	Portable transfer - poly fill gun
TU-20N-SSW	Portable transfer - stainless wand
TU-20N-CSSW	Portable transfer - curved stainless wand



Pictured: PFG



25 Gallon (94.6 Liter)

TU-25N-PFG	Portable transfer - poly fill gun
TU-25N-SSW	Portable transfer - stainless wand
TU-25N-CSSW	Portable transfer - curved stainless wand



Pictured: SSW



30 Gallon (113.6 Liter)

TU-30N-PFG	Portable transfer - poly fill gun
TU-30N-SSW	Portable transfer - stainless wand
TU-30N-CSSW	Portable transfer - curved stainless wand



Pictured: CSSW

see more units & options at foamit.com





Locking Cap Jugs

2.5 Gallon (9.5 Liter)



Product	- Capacity	Tank Color	- Cap Color	- Suction	Rack
Jug (JGA)	2.5 Gallon (2.5)	Natural (N)	Black (LIBK)	None (standard)	None (standard)
			Blue (LIBL)		
			Brown (LIBN)	Suction (S)	Rack (R)
			Green (LIGN)	Locking Rack (LIR)	
			Orange (LIOR)		
			Purple (LIPL)		
			Red (LIRD)		
			White (LIWH)		
			Yellow (LIYL)		

Examples:

- JGA-2.5N-LIBK-S - 2.5 gallon natural jug with black locking cap, and suction
- JGA-2.5N-LIYL - 2.5 gallon natural jug with yellow locking cap



5 Gallon (18.9 Liter)



Product	- Capacity	Tank Color	- Cap Color	- Suction	Rack
Jug (JGA)	5 Gallon (5)	Natural (N)	Black (LIBK)	None (standard)	None (standard)
			Blue (LIBL)		
			Brown (LIBN)	Suction (S)	Rack (R)
			Green (LIGN)	Locking Rack (LIR)	
			Orange (LIOR)		
			Purple (LIPL)		
			Red (LIRD)		
			White (LIWH)		
			Yellow (LIYL)		

Examples:

- JGA-5N-LIBK-S - 5 gallon natural jug with black locking cap, and suction
- JGA-5N-LIGN - 5 gallon natural jug with green locking cap

Non-locking Cap Jugs

2.5 Gallon (9.5 Liter)



Product	- Capacity	Tank Color	- Cap Color	- Suction	Rack
Jug (JGA)	2.5 Gallon (2.5)	Natural (N)	Black (CPBK)	None (standard)	None (standard)
			Blue (CPBL)		
			Brown (CPBN)	Suction (S)	Rack (R)
			Green (CPGN)	Locking Rack (LIR)	
			Orange (CPOR)		
			Purple (CPPL)		
			Red (CPRD)		
			White (CPWH)		
			Yellow (CPYL)		

Examples:

- JGA-2.5N-CPBK-SR - 2.5 gallon natural jug with black cap, suction, and rack
- JGA-2.5YL-CPYL - 2.5 gallon yellow jug with yellow cap



5 Gallon (18.9 Liter)



Product	- Capacity	Tank Color	- Cap Color	- Suction	Rack
Jug (JGA)	5 Gallon (5)	Natural (N)	Black (CPBK)	None (standard)	None (standard)
			Blue (CPBL)		
			Brown (CPBN)	Suction (S)	Rack (R)
			Green (CPGN)	Locking Rack (LIR)	
			Orange (CPOR)		
			Purple (CPPL)		
			Red (CPRD)		
			White (CPWH)		
			Yellow (CPYL)		

Examples:

- JGA-5N-CPBK-SR - 5 gallon natural jug with black cap, suction, and rack
- JGA-5RD-CPWH - 5 gallon red jug with red cap





Locking Caps

Fine Thread

LICPA-BK-FT-NVNT	Jug with Locking cap, no suction
LICPA-BK-FT-VNT	Jug with Locking cap and suction
LICPA-BK-S-FT-NF	Knockout only, no suction
LICPA-BK-S-FT	Knockout with suction fitting

Buttress Thread

LICPA-BK-S-BT-NF	Knockout only, no suction
LICPA-BK-S-BT	Knockout with suction fitting
LICPA-BK-BT-NVNT	Unvented locking cap



Color Options								
Black (BK)	Blue (BL)	Brown (BN)	Green (GN)	Orange (OR)	Purple (PL)	Red (RD)	White (WH)	Yellow (YL)

see more units & options at foamit.com

Racks + Stands

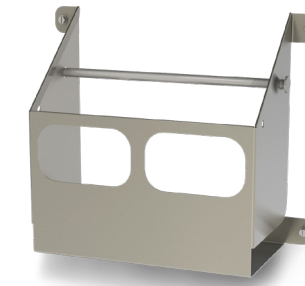

Container Locking Rack

WMA-2X1-LI	Wall mounted locking rack - holds two 1-gallon containers
------------	---



Jug Rack

WMBRKT-JG	Wall mounted rack - holds one 5 or 10 gallon chemical jug
-----------	---

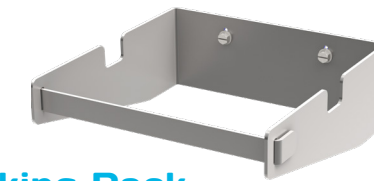

Jug Locking Rack

WMBRKT-JG-LI	Wall mounted locking rack - holds one 5 or 10 gallon chemical jug
--------------	---



Stand

BSA-CMS12X12	Slide-out base stand - holds 12 x 12 in. container
--------------	--





Pump-Up Units

Manual Powered - p.34
Dual Powered - p.35
Drain Units - p.36

Pump-Ups

For smaller jobs and those hard-to-reach places, our manual pump-up units bring quality chemistry output wherever it's needed.

Pump-up units have Viton seals for the best possible chemical compatibility. For five and ten liter models, choose between an extendable wand or heavy-duty polypropylene trigger gun to match your cleaning program's application needs.

Our 1.5-liter pump-ups replace common squeeze-trigger bottles. Ergonomically designed with a thumb trigger to reduce wrist fatigue, these make quick work of small cleaning tasks.



foam



spray



fog + mist

The Good Stuff

- **Small size, big performance**
Same high quality output in a small convenient unit.
- **Natural tank**
See chemical volume levels at a glance.
- **Maximizing portability**
When you need to clean specific surfaces, our pump up-units are there. Even apply chemistry to those hard to reach areas.



F1.5L

F5.0L



Manual Power



**0.4 Gallon
(1.5 Liter)**

F1.5L	● Foam - white tank
SP1.5L	● Spray - white tank
MU1.5L	● Mist - white tank



**0.4 Gallon
(1.5 Liter)**

F1.5LBK	● Foam - black tank
SP1.5LBK	● Spray - black tank
MU1.5LBK	● Mist - black tank



**1.3 Gallon
(5 Liter)**

F5.0L	● Foam - extendable wand
SP5.0L	● Spray - extendable wand
MU5.0L	● Mist - extendable wand



**2.6 Gallon
(10 Liter)**

F10.0L	● Foam - extendable wand
SP10.0L	● Spray - extendable wand
MU10.0L	● Mist - extendable wand



**1.3 Gallon
(5 Liter)**

F5.0L-PSG	● Foam - heavy duty trigger handle
SP5.0L-PSG	● Spray - heavy duty trigger handle



**2.6 Gallon
(10 Liter)**

F10.0L-PSG	● Foam - heavy duty trigger handle
SP10.0L-PSG	● Spray - heavy duty trigger handle

see more units & options at foamit.com

Dual Power

We developed the Dual-Power version of our 10-liter pump-up to ensure pressure never drops. Hook up compressed air for steady pressure or for initial charging of the unit; if air becomes unavailable, manually pump it up to keep working.

In addition to our foam and spray assemblies, we designed dairy-specific units for hoof and teat treatments.



see more details



**2.6 Gallon
(10 Liter)**

F100	● Dual power foam
SP100	● Dual power spray



Plunger

F100-DF	● Dual power foam - drain plunger
---------	-----------------------------------



Hoof

F100-HF	● Dual power foam - hoof attachment
---------	-------------------------------------



Teat Cup

F100-TF	● Dual power foam - teat attachment
---------	-------------------------------------





Drain Foaming

Biofilm in drains harbor pests, odors, and dangerous pathogens. Unlike liquid cleaners, foam expands inside pipes to contact the entire internal surface area – for 360° coverage. Foam pushes through pipes, reaching deep into the plumbing network.

Plus, foam breaks down slowly, giving chemistry optimal time to work.

Our manually powered drain foam units maximize portability to treat drains of various sizes and locations.



.75 Inch
(19 mm)

F1.5LBK-DP.75	● Manual powered foam - black tank
F1.5L-DP.75	● Manual powered foam - white tank



3.75 Inch
(9.5 cm)

F1.5LBK-DP3.75	● Manual powered foam - black tank
F1.5L-DP3.75	● Manual powered foam - white tank



2.6 Gallon
(10 Liter)

F100-DF	● Dual power foam - drain plunger
---------	-----------------------------------



Plunger Attachment

DPA-PUF	● 5 in. (12.7 cm) diameter plunger attachment
---------	---



Attachments

Drain Foam - p.40
Belt Foam Bar - p.41

Attachments

From drains to conveyor belts, we make foam attachments to clean them. All portable units can be adapted with quick connect fittings, allowing users to switch between attachments and wands easily.

Seeing the need for CIP conveyor belt cleaning options, our engineering team developed the Belt Foam Bar in six lengths. The Belt Foam Bar attaches to our portable units with a quick-connect fitting valve so you can quickly move between belts. A rinse bar assembly is also available.

Our Drain Foaming Attachments come in a variety of heights and drain cover shapes for circular, trench, and square floor drains.



foam

The Good Stuff

- **Attachments made easy**
Connect to compatible units using easy quick-connect fittings.
- **Versatility for every task**
Attachments come in a variety of shapes and sizes to fit all your needs.
- **Adaptable cleaning**
Switch between different foam attachments for various tasks.



DFA

DFA-36



Drain Foam



Round

DFA	● Drain foam attachment - 48 in.
DFA-36	● Drain foam attachment - 36 in.



Trench

DFA	● Drain foam attachment - trench drains 7 in. dia brush
-----	---



Square

DFA-SQ13	● Drain foam attachment - 48 in. - square disc
----------	--



Plunger

DPA-PUF	● 5 in. (12.7 cm) diameter plunger attachment
---------	---

Belt Foam Bar

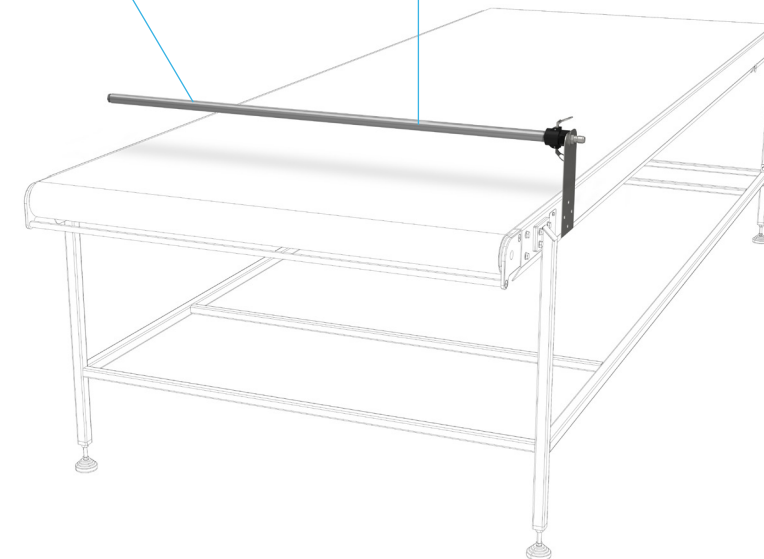
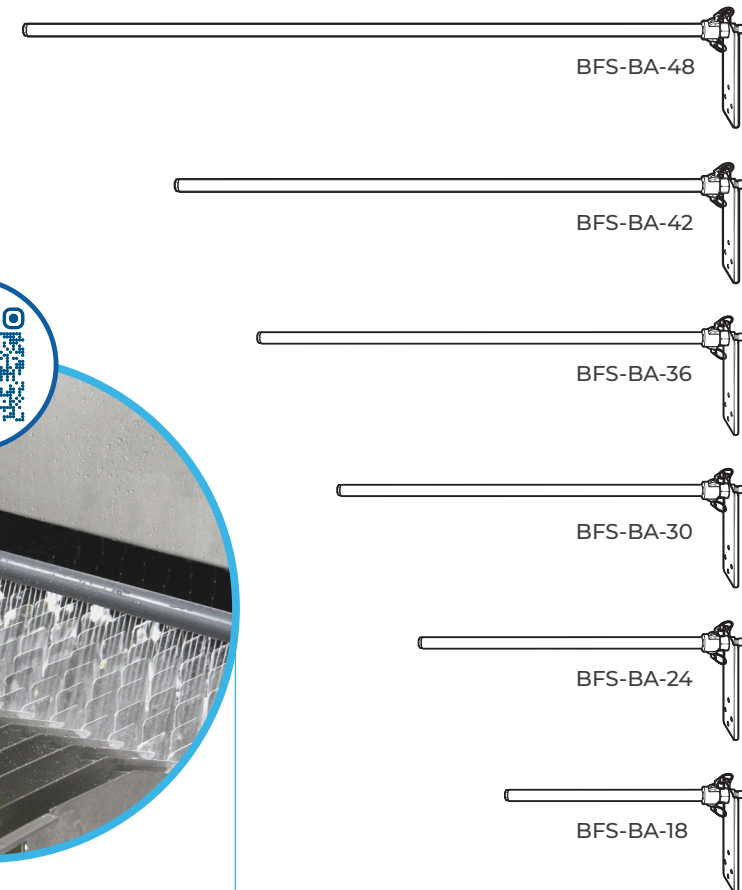

Attachments

Attachments



Innovative Units

Drum Rinse - p.44
Flooded Suction Tank - p.45

Innovations

We love a good challenge. Sometimes innovations are born from custom projects, other times we identify a way we could make "it" better for our customers and end users.

Have a unique need? Reach out to our team and we will partner with you to develop a solution.

Call us: 800 567 5420

Email us: sales@foamit.com

Find us:   

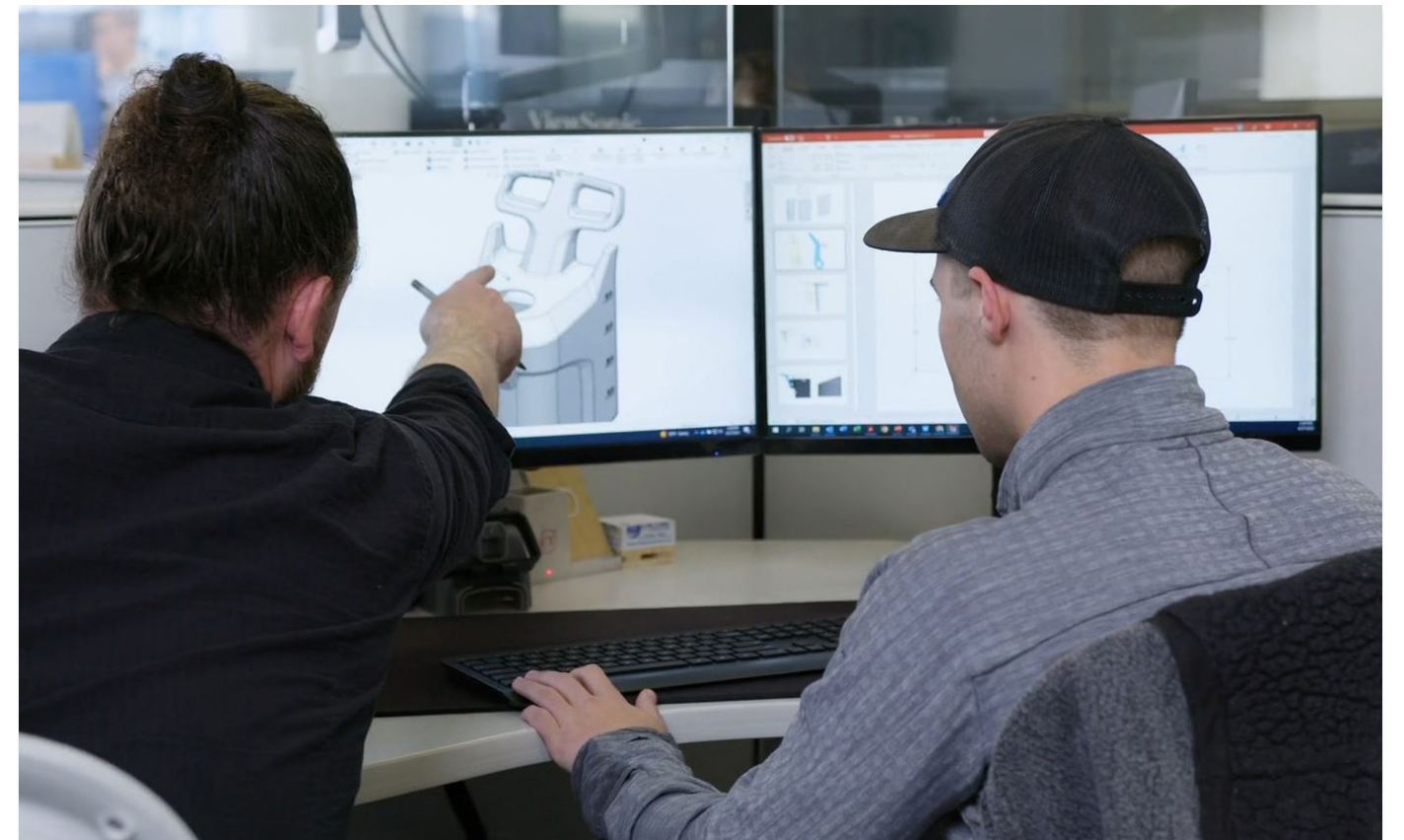



Drum Rinse

Save labor, time, and water expenses when rinsing 15-, 30-, and 55- gallon drums. Just load the drum, select the triple rinse cycle, let it run, and remove the rinsed drum. Boosted water pressure version also available, please see your salesperson for more information.



see more details

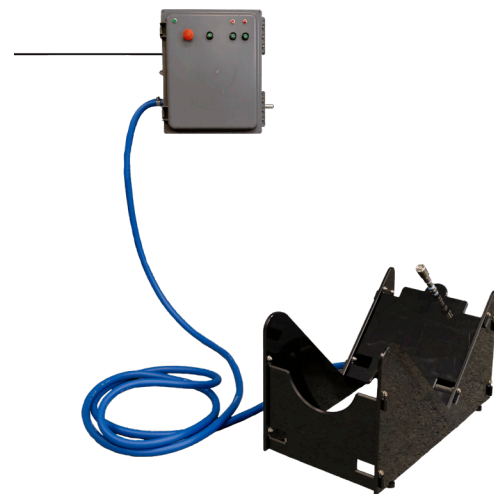

Drum Rinse

DRS	Drum rinse system for 15, 30, 55 gallon containers
-----	--

Flooded Suction Tank

Keeping dosing pumps primed is key for consistent dilution rates and pump longevity. The flooded suction tank (FST) has been refreshed by our engineering team to include more robust safety valves, easy-to-access components, and hook ups for external chemical monitoring software.



see more details



FST

FST	Flooded Suction Tank
-----	----------------------





Color Options

Color Options

Black (BK)	Blue (BL)	Brown (BN)	Green (GN)	Orange (OR)	Purple (PL)	Red (RD)	White (WH)	Yellow (YL)
---------------	--------------	---------------	---------------	----------------	----------------	-------------	---------------	----------------

- 1 Hinged lid
● ● ● ● ● ● ● ● ● ●
- 2 Hose
● ● ● ● ● ● ● ● ● ●
- 3 Locking cap
● ● ● ● ● ● ● ● ● ●
- 4 Non-locking cap
● ● ● ● ● ● ● ● ● ●
- 5 Non-locking jug
● ● ● ● ● ● ● ● ● ●

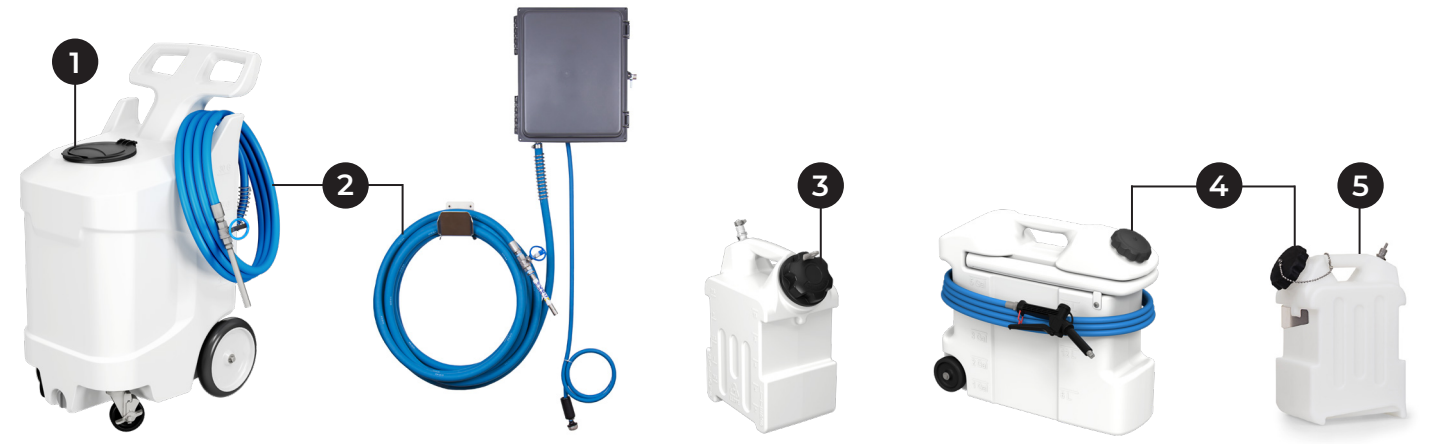

Made easy for you

We offer a wide selection of units to suit your style and needs. If we don't have exactly what you're looking for, our tech team is ready to customize a unit just for you.

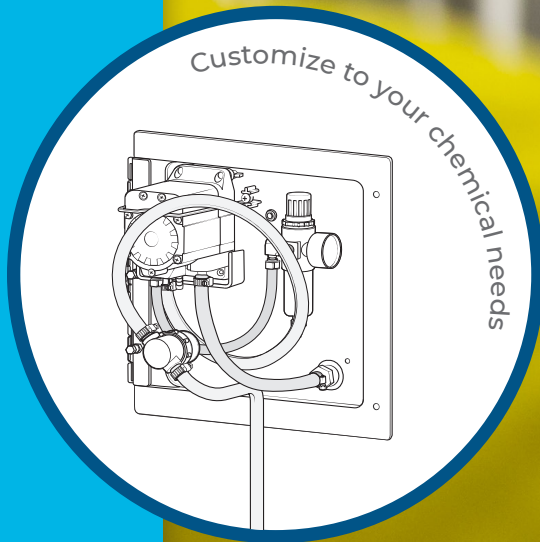
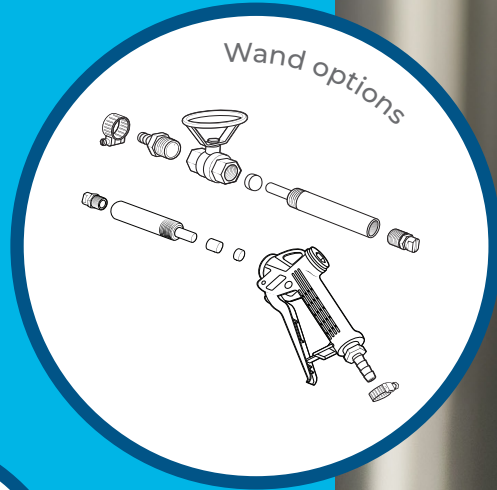

FOAMit

sales@foamit.com

800 567 5420



FOAMit

product catalog